



WOODSMAN

Handcrafted in New Zealand

since 1887



Welcome

The Woodsman Story	3
The Woodsman Legacy	4-5
Trees That Count	6
Built to Last, Designed for New Zealand	7
Heating Space Calculator	10-11
The Woodsman Range	12-13
Serene Petite	14-15
Kanaku	16-17
Serene	18-19
Coleridge	20-21
Flare	22-23
Tasman MkII	24-25
Tarras MkIII	26-27
Totara	28-29
Multi-fuel - Strongman	30
Multi-fuel - RMF	31
Multi-fuel - The Stag	32
Multi-fuel - The Coaster	33
Parts & Accessories	34





WOODSMAN

Handcrafted in New Zealand since 1887.

As long as people have gathered, it has been around fire. A reprieve from the cold, a beacon in the dark.

Since 1887, Woodsman has continued that connection, crafting wood burners from New Zealand Steel, forged from the black sands of the West Coast. We have always designed and manufactured here in New Zealand to build wood burners suited to our climate and the way we live. Every product carries the influence of the place it's made and the expectation it will stand the test of time. We will continue to pioneer designs that deserve their place at the heart of New Zealand homes.



1904 - Japanning Shop at 45 Colombo Street
W.H. Harris on right



1904 Premises at 45 Colombo Street
(numbered from Moorhouse Ave - later 563 Colombo St.)

Family history. A real legacy.

Woodsman wood burners are designed and handcrafted in New Zealand by W.H.Harris. We've been warming Kiwi homes since 1887.

A real family business that spans five generations, we remain committed to handcrafting your Woodsman fire to the most exacting standards, using generations of collected experience to deliver outstanding craftsmanship.



Started partnership in these premises at 113 Litchfield Street in 1887 as Harris and Wood, Plumbers, Gasfitters and Tinsmiths. W.H.Harris bought out his partner in 1890.



W.H.Harris

FOUNDER



Supporting our native forests.

We're committed to a future where our native forests flourish; that's why we've partnered with Trees That Count, New Zealand's leading native tree funding platform. This partnership allows us to support science-led, ecologist-overseen planting projects. Every dollar funded provides a transparent and measurable way for Woodsman to give back to Aotearoa. It's a simple, authentic commitment to our environment, ensuring a growing legacy for generations of Kiwis to come.





15yr

**WOODB
BOX
WARRANTY**

2yr

**PARTS
WARRANTY**

Built to last, designed for New Zealand.

Every Woodsman is crafted for the realities of New Zealand living - from coastal winds to alpine winters. Our fires are built from NZ-made steel and premium materials chosen for strength, stability and long service life. Hand-assembled by our team in Christchurch, each fire carries generations of knowledge and the expectation that it will perform reliably for decades.

We stand behind that craftsmanship with industry leading warranties and a full range of replacement parts, ensuring your Woodsman keeps heating your home beautifully for as long as home wood fires keep burning.



WOODSMAN



**A southern
range, through
and through.**



Heating Space Calculator

Calculate with real precision which Woodsman feels right for your home.

Our simple four step process will help you identify the Woodsman fires that are ideal for your home using W.H.Harris' proven calculation system.

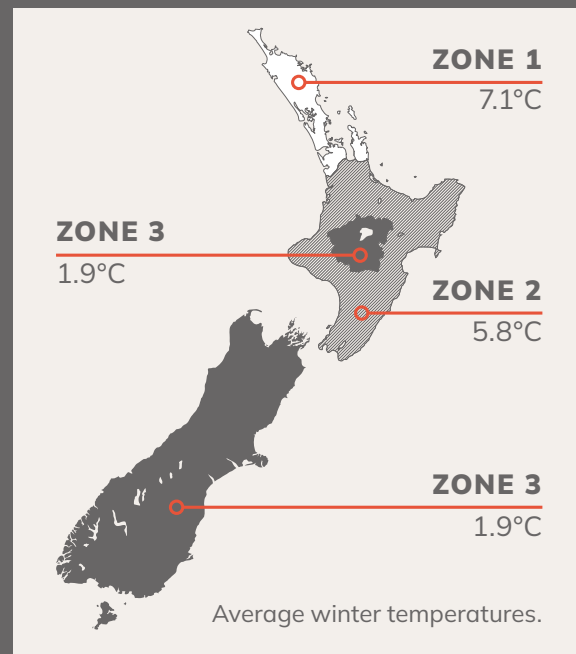

How does this calculator work?

The Heating Space Calculator is based on maintaining a comfortable room temperature of 23°C with a 2.4m ceiling height. It does this

by estimating the 'Heat Loss Value (kW)' – taking into account your region, age of home and room dimensions – what we like to call 'the sweet spot.'

WHY IS THIS CALCULATION SYSTEM PREFERRED? REAL DATA VS PEAK MOMENT.

Wood fires do not produce a constant heat output. After loading wood, the output will increase dramatically and then cool down significantly before you reload again.

This calculation system shows an average output taking into consideration the peaks and troughs and gives a genuine figure as to how much heat you will get out of the fire over a typical burn cycle.

While some brands represent their outputs at 'Peak', which is the very top of the heating curve, we prefer to show an accurate representation of a fire's true performance over time.

A calculator based on average output (like the one below) gives you a real performance value and lets you feel confident about correctly heating your chosen space.

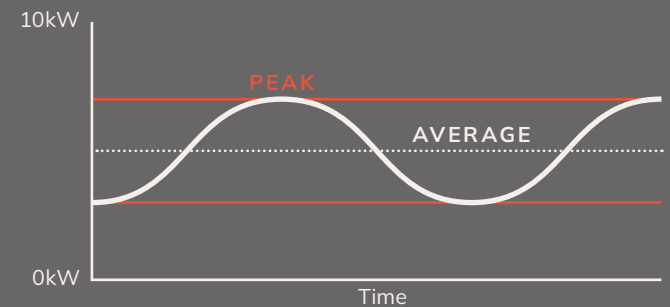

**STEP 1
SELECT YOUR ZONE**

In which zone do you live?
The country is divided into three areas according to the average daily minimum outdoor air temperature.

**STEP 2
SELECT THE AGE
OF YOUR HOME**

This will determine insulation levels.
If your home insulation has been upgraded or double glazing has been retrofitted, choose the next category up.

**STEP 3
SELECT THE M² SIZE OF
YOUR HEATING SPACE**

Be realistic when choosing this size. Match the area to the space you are trying to heat, and bear in mind these calculations are based on a ceiling height of 2.4m.

**STEP 4
FIND YOUR WOODSMAN**

Finally, use this kilowatt number to identify the wood burners (on the following page) that best match your needs. Your ideal models will have a high and low kW output on either side of this number.

ZONE 1



Age of Home	10m ²	20m ²	30m ²	40m ²	50m ²	60m ²	70m ²	80m ²	90m ²	100m ²	110m ²	120m ²	130m ²	140m ²	150m ²	160m ²	170m ²	180m ²	190m ²	200m ²
Pre 1978	2.2kW	3.5kW	4.6kW	5.6kW	6.5kW	7.5kW	8.4kW	9.3kW	10.1kW	11.1kW	11.8kW	12.7kW	13.5kW	14.3kW	15.1kW	15.9kW	16.7kW	17.4kW	18.2kW	19kW
1978–1996	1.7kW	2.5kW	3.3kW	4kW	4.6kW	5.2kW	5.8kW	6.3kW	6.9kW	7.4kW	7.9kW	8.5kW	9kW	9.5kW	10kW	10.4kW	10.9kW	11.4kW	11.9kW	12.3kW
1996–2004	1.4kW	2.1kW	2.7kW	3.3kW	3.8kW	4.3kW	4.8kW	5.2kW	5.7kW	6.1kW	6.5kW	6.9kW	7.3kW	7.7kW	8.1kW	8.5kW	8.9kW	9.3kW	9.6kW	10kW
2004–2009	1.6kW	2.4kW	3.1kW	3.6kW	4.2kW	4.7kW	5.2kW	5.7kW	6.2kW	6.6kW	7.1kW	7.5kW	7.9kW	8.3kW	8.7kW	9.2kW	9.6kW	9.9kW	10.3kW	10.7kW
Post 2009	1kW	1.6kW	2kW	2.5kW	2.9kW	3.3kW	3.6kW	4kW	4.3kW	4.7kW	5kW	5.3kW	5.6kW	6kW	6.3kW	6.6kW	6.9kW	7.2kW	7.5kW	7.8kW

ZONE 2



Age of Home	10m ²	20m ²	30m ²	40m ²	50m ²	60m ²	70m ²	80m ²	90m ²	100m ²	110m ²	120m ²	130m ²	140m ²	150m ²	160m ²	170m ²	180m ²	190m ²	200m ²
Pre 1978	2.4kW	3.7kW	4.9kW	6kW	7.1kW	8.1kW	9kW	10kW	10.9kW	11.8kW	12.8kW	13.6kW	14.5kW	15.4kW	16.3kW	17.1kW	18kW	18.8kW	19.7kW	20.5kW
1978–1996	1.8kW	2.7kW	3.6kW	4.3kW	5kW	5.6kW	6.2kW	6.8kW	7.4kW	8kW	8.6kW	9.1kW	9.7kW	10.2kW	10.7kW	11.3kW	11.8kW	12.3kW	12.8kW	13.3kW
1996–2004	1.5kW	2.3kW	3kW	3.6kW	4.1kW	4.6kW	5.1kW	5.6kW	6.1kW	6.6kW	7kW	7.5kW	7.9kW	8.3kW	8.7kW	9.2kW	9.6kW	10kW	10.4kW	10.8kW
2004–2009	1.7kW	2.6kW	3.3kW	3.9kW	4.5kW	5.1kW	5.6kW	6.2kW	6.7kW	7.1kW	7.6kW	8.1kW	8.5kW	9kW	9.4kW	9.9kW	10.3kW	10.7kW	11.2kW	11.6kW
Post 2009	1.1kW	1.7kW	2.2kW	2.7kW	3.1kW	3.5kW	3.9kW	4.3kW	4.7kW	5kW	5.4kW	5.7kW	6.1kW	6.4kW	6.8kW	7.1kW	7.4kW	7.8kW	8.1kW	8.4kW

ZONE 3



Age of Home	10m ²	20m ²	30m ²	40m ²	50m ²	60m ²	70m ²	80m ²	90m ²	100m ²	110m ²	120m ²	130m ²	140m ²	150m ²	160m ²	170m ²	180m ²	190m ²	200m ²
Pre 1978	2.9kW	4.5kW	6kW	7.3kW	8.6kW	9.8kW	11kW	12.2kW	13.3kW	14.5kW	15.6kW	16.6kW	17.7kW	18.8kW	19.9kW	20.9kW	21.9kW	23kW	24kW	25kW
1978–1996	2.2kW	3.4kW	4.3kW	5.2kW	6.1kW	6.9kW	7.6kW	8.4kW	9.1kW	9.8kW	10.5kW	11.2kW	11.8kW	12.5kW	13.1kW	13.8kW	14.4kW	15kW	15.7kW	16.3kW
1996–2004	1.8kW	2.7kW	3.4kW	4.1kW	4.7kW	5.4kW	5.9kW	6.5kW	7kW	7.6kW	8.1kW	8.6kW	9.1kW	9.6kW	10.1kW	10.5kW	11kW	11.5kW	11.9kW	12.4kW
2004–2009	1.4kW	2.1kW	2.7kW	3.3kW	3.8kW	4.4kW	4.8kW	5.3kW	5.8kW	6.3kW	6.7kW	7.1kW	7.6kW	8kW	8.4kW	8.9kW	9.3kW	9.7kW	10.1kW	10.5kW
Post 2009	1.3kW	2kW	2.6kW	3.2kW	3.7kW	4.2kW	4.7kW	5.1kW	5.6kW	6kW	6.4kW	6.9kW	7.3kW	7.7kW	8.1kW	8.5kW	8.9kW	9.3kW	9.6kW	10kW

Woodsman, the range.

Real craft. Quality you
can feel. Built to last.

ROBUST CERAMIC GLASS

Highest quality glass supplied by SCHOTT ROBAX®, leaders in fireplace glass.

NEW ZEALAND MADE MILD STEEL

6-8mm steel plate used for high construction strength and ultimate firebox longevity.

LONG LASTING PARTS

Use of only the best materials to ensure maximum life of consumable parts.

TOUGH FIRE BRICKS

Long lasting, compressed Vermiculite SKAMOLEX™ fire bricks, designed to withstand extreme temperatures.

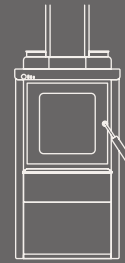

SERENE PETITE

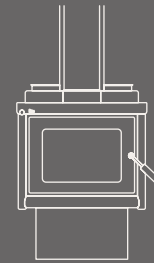

KANAKU
PEDESTAL

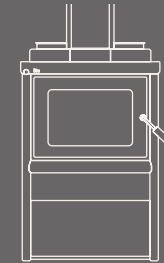

KANAKU
WOOD BOX

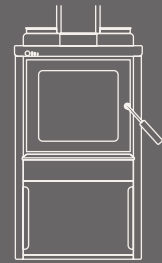

SERENE

	SERENE PETITE		KANAKU PEDESTAL		KANAKU WOOD BOX		SERENE	
	HIGH	LOW	HIGH	LOW	HIGH	LOW	HIGH	LOW
A	6.2 kW	4.5 kW	9.0 kW	8.0 kW	9.0 kW	8.0 kW	8.5 kW	6.2 kW
B	1.85 kg/h	1.17 kg/h	2.0 kg/h	1.8 kg/h	2.0 kg/h	1.8 kg/h	2.38 kg/h	1.65 kg/h
C	60.7%	70.6%	69.0%	79.0%	69.0%	79.0%	63.8%	67.9%
D	25.7L		26.2L		26L		46.7L	
E	834H × 411W × 555D		699H × 502W × 473D		800H × 502W × 474D		928H × 501W × 613D	
F	300 mm		350 mm		350 mm		400 mm	
G	Up to 4		Up to 3		Up to 3		Up to 6	
H	ULEB	NES	ULEB	NES	ULEB	NES	ULEB	NES
I	✓	✓	✓	✓	✓	✓	✓	✓
J	0.35g/kg		0.3g/kg		0.3g/kg		0.36g/kg	
K	66.2%		74%		74%		66.2%	
L	X		X		X		2 kW (estimated)	
	2Y Parts	15Y Firebox	2Y Parts	15Y Firebox	2Y Parts	15Y Firebox	2Y Parts	15Y Firebox

A Average Heat Output
B Fuel Consumption Rate
C Room Heating Efficiency
D Firebox Volume

E Fire Dimensions
F Max. Log Length
G Approx No. Logs
H Clean Air Approval

I Average Emissions
J Average Efficiency
K Wetback Approved
L Warranty

For more information, visit woodsman.co.nz



COLERIDGE

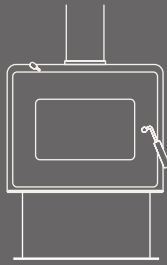

FLARE

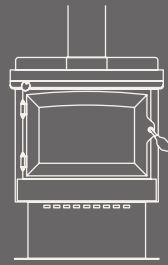

TASMAN MKII

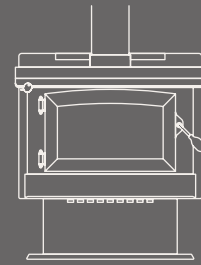

TARRAS MKIII

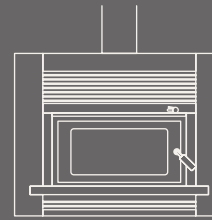

TOTARA

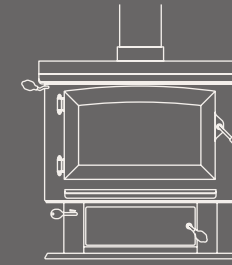

STRONGMAN

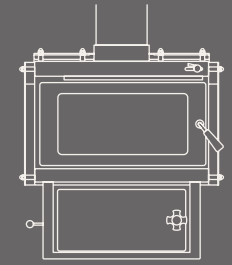

RMF

HIGH	LOW
8.9 kW	7.5 kW
2.55 kg/h	1.94 kg/h
62.3%	69.6%

HIGH	LOW
12.0 kW	9.1 kW
3.38 kg/h	2.27 kg/h
64.1%	72.4%

HIGH	LOW
14.3 kW	8.4 kW
4.04 kg/h	2.05 kg/h
64.4%	78.1%

HIGH	LOW
16.9 kW	10.6 kW
4.86 kg/h	2.56 kg/h
63.1%	74.1%

HIGH	LOW
7.3 kW	4.7 kW
2.26 kg/h	1.13 kg/h
57.5%	75.2%

A
D
E
F
G
K
L

HIGH	LOW
18 kW	11 kW
76L	
697H x 715W x 590D	
600 mm	
Up to 8	
3/5 kW (estimated)	
2Y Parts	15Y Firebox

HIGH	LOW
11 kW	8 kW
32L	
618H x 580W x 450D	
350 mm	
Up to 3	
2.5 kW (estimated)	
2Y Parts	15Y Firebox

60.5L
823H x 648W x 638D
450 mm
Up to 7

55.5L
780H x 630W x 602D
450 mm
Up to 6

55.6L
808H x 615W x 630D
450 mm
Up to 6

75.3L
824H x 765W x 640D
600 mm
Up to 10

32.5L
650H x 840W x 62D
450 mm
Up to 2

ULEB	NES
✓	✓
0.49g/kg	
66.3%	
X	
2Y Parts	15Y Firebox

ULEB	NES
X	✓
0.97g/kg	
68%	
2 kW (estimated)	
2Y Parts	15Y Firebox

ULEB	NES
X	✓
0.5g/kg	
71%	
2 kW (estimated)	
2Y Parts	15Y Firebox

ULEB	NES
X	✓
0.37g/kg	
69%	
3 kW (estimated)	
2Y Parts	15Y Firebox

ULEB	NES
X	✓
0.9g/kg	
67%	
X	
2Y Parts	15Y Firebox

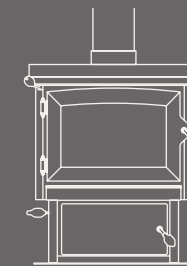

THE STAG

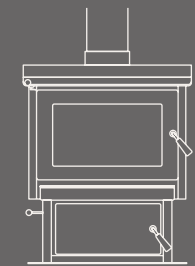

THE COASTER

HIGH	LOW
15 kW	9 kW
56L	
727H x 615W x 622D	
400 mm	
Up to 6	
3 kW (estimated)	
2Y Parts	15Y Firebox

HIGH	LOW
15 kW	9 kW
56L	
727H x 615W x 622D	
400 mm	
Up to 6	
3 kW (estimated)	
2Y Parts	15Y Firebox

A
D
E
F
G
K
L

ULTRA LOW EMISSION BURNER

ULEBs are the cleanest solid fuel burners. Under the current Air Plan, they can be installed and used indefinitely in Canterbury. ULEBs are tested using the Canterbury Method 1 (CM1), which uses strict real-life operating conditions.

NATIONAL ENVIRONMENTAL STANDARDS

NES are set by the Ministry for the Environment, September 2005. All new wood fires must meet a minimum efficiency level of 65%, plus include emissions of less than 1.5gm of carbon per kg of burnt dry wood. This covers the whole country as the MINIMUM level of compliance – some districts have implemented more stringent levels of compliance.

Serene Petite

Freestanding Ultra
Low Emission Burner

26L

FIREBOX
CAPACITY

4 log

FIREBOX
CAPACITY

8mm

STEEL
COOKTOP

15yr

WOODB
WARRANTY

2yr

PARTS
WARRANTY

Feels streamlined,
sleek and petite –
a smaller form
factor, built to
nestle neatly.



Height 834

Width 411

Depth 555

Enjoy the traditional comfort of a log fire with the benefit of sustained burn technology, heating your home to a pleasant, even temperature – delivering more fire power from each piece of wood.

CRAFTED FOR A LONG LIFE

The Serene Petite is fitted with stainless steel air tubes and baffle for long service life and comes with a two year warranty.

ULTRA LOW EMISSIONS – FEEL BETTER ABOUT THE ENVIRONMENT

The Serene Petite outperforms the testing standards for emissions, meaning it can be installed in any New Zealand home.



EASY TO LIGHT AND CLEAN

With built-in storage to reduce clutter, the Serene Petite's design is ergonomic and promotes cost-effective ease of use.

GENEROUSLY SIZED FIRE BOX

Fits up to 4 standard sized logs (approx. 120mm x 120mm x 300mm) and the sustained burn technology will keep you warmer for longer on each load of fuel.

SIMPLE TO LOAD FRONT-TO-BACK FIREBOX

The front to back orientation ensures protection from logs rolling out.

HANDY STEEL COOKTOP

The Serene Petite is fitted with a convenient 8mm steel cooktop suitable for use during a power outage.

Dimensions	834H x 411W x 555D	
Weight	110 kg	
ULEB Approved	Yes	
Clean Air Approval	All Zones	
Floor Protector	Ash Hearth	
Max. Log Length	300 mm	
Approx No. Logs	Up to 4	
	High	Low
Average Heat Output	6.2 kW	4.5 kW
Fuel Consumption Rate	1.85 kg/h	1.17 kg/h
Room Heating Efficiency	60.7%	70.6%

The Serene Petite requires no electrical installation, no additional components and no complex operating requirements.

WALL INSTALLATION

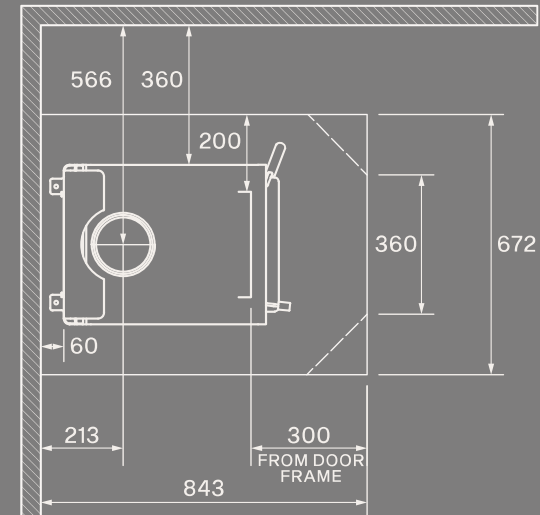

All dimensions and clearances are in mm.
Clearances are with factory flue shield.

CORNER INSTALLATION

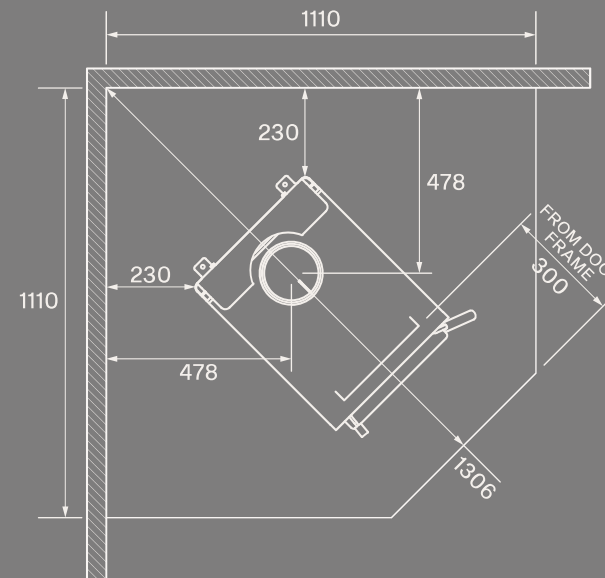

Refer to installation manual for full specifications.

Kanaku

Freestanding Ultra Low Emission Burner

26L

FIREBOX
CAPACITY

3 log

FIREBOX
CAPACITY

8mm

STEEL
COOKTOP

15yr

WOODB
WARRANTY

2yr

PARTS
WARRANTY

Feels simple and elegant. Ideal for any Kiwi home.

Simplicity is the key and the Kanaku achieves ultra clean burning without the need for fans, or other types of systems which require special operational methods or additional maintenance. Available in two options Pedestal and Wood Box.

CRAFTED FOR A LONG LIFE

The Kanaku is fitted with stainless steel air tubes and baffle for long service life which has a two year warranty.

ULTRA LOW EMISSIONS – FEEL BETTER ABOUT THE ENVIRONMENT

The Kanaku outperforms the testing standards for emissions, meaning it can be installed in any New Zealand home.



	Pedestal	Woodbox
Height	699	800
Width	502	502
Depth	473	474



USER FRIENDLY & EASY TO MAINTAIN

Kanaku's design is ergonomic and promotes cost-effective ease of use.

EASY SERVICE

The simple baffle removal system ensures easy servicing for chimney sweeps.

Dimensions – Pedestal	699H × 502W × 473D	
– Wood Box	800H × 502W × 474D	
Weight	100 kg	
ULEB Approved	Yes	
Clean Air Approval	All Zones	
Floor Protector	Ash Hearth	
Max. Log Length	350 mm	
Approx No. Logs	Up to 3	
	High	Low
Average Heat Output – Pedestal	9.0 kW	8.0 kW
Fuel Consumption Rate	2.0 kg/h	1.8 kg/h
Room Heating Efficiency	69.0%	79.0%

The Kanaku requires no electrical installation, no additional components and no complex operating requirements.

WALL INSTALLATION

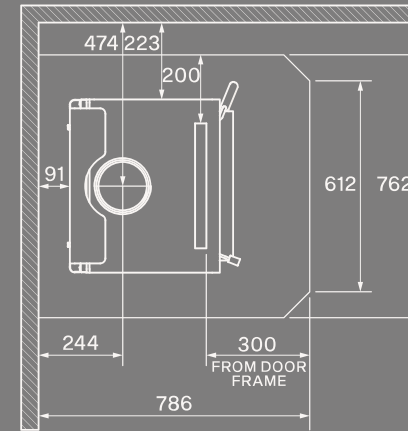

PEDESTAL

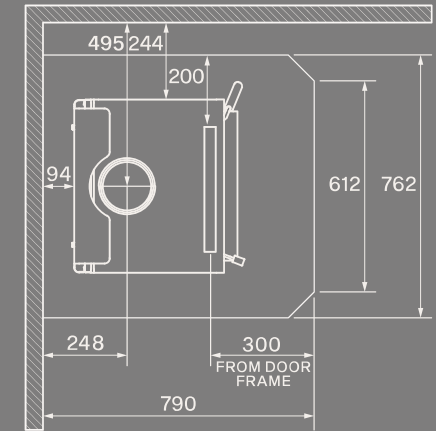

WOOD BOX

All dimensions and clearances are in mm. Clearances are with factory flue shield.

CORNER INSTALLATION

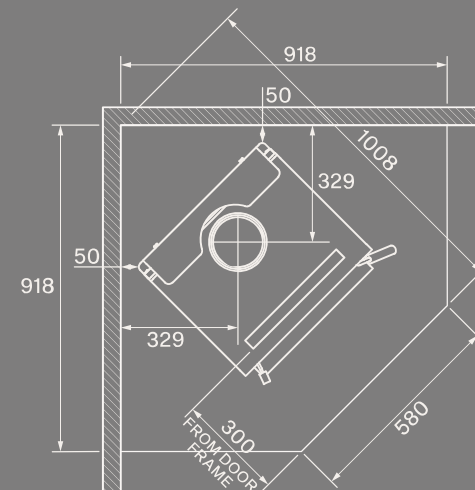

PEDESTAL

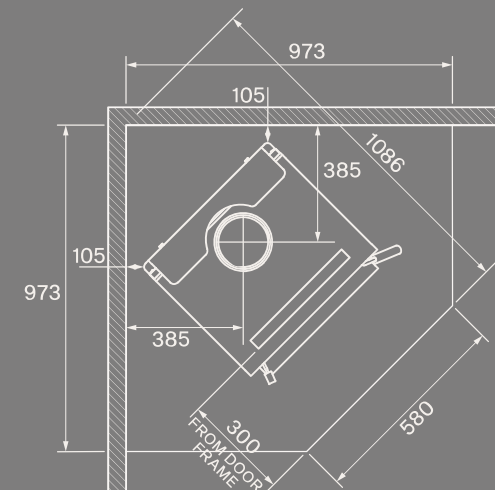

WOOD BOX

Refer to installation manual for full specifications.

Serene

Freestanding Ultra Low Emission Burner

47L

FIREBOX
CAPACITY

6 log

FIREBOX
CAPACITY

8mm

STEEL
COOKTOP

15yr

WOODB
WARRANTY

2yr

PARTS
WARRANTY

Feels streamlined and sleek – a trim form factor, built to nestle neatly.



Height	928
Width	501
Depth	613

Enjoy the traditional comfort of a log fire with the benefit of sustained burn technology, heating your home to a pleasant, even temperature. Feel more fire power from each piece of wood.

CRAFTED FOR A LONG LIFE

The Serene is fitted with stainless steel air tubes and baffle for long service life and comes with a two year warranty.

ULTRA LOW EMISSIONS – FEEL BETTER ABOUT THE ENVIRONMENT

The Serene outperforms the testing standards for emissions and wetback use, meaning it can be installed in any New Zealand home.

DRAWER

The Serene Drawer includes a no mess ash scoop. This scoop fits neatly into the fire-safe drawer, which has room for kindling and fire-starting tools.



EASY TO LIGHT AND CLEAN

With built-in storage to improve safety and reduce clutter, the Serene's design is ergonomic and promotes cost-effective ease of use.

UPRIGHT LOAD AND LIGHT HEIGHT

When loading wood or cleaning, the Serene is accessed at standing height without the need for crouching or kneeling.

HANDY STEEL COOKTOP

The Serene is fitted with a convenient 8mm steel cooktop suitable for use during a power outage.

Dimensions	928H × 501W × 613D	
Weight	145 kg	
ULEB Approved	Yes	
Clean Air Approval	All Zones	
Floor Protector	Ash Hearth	
Max. Log Length	400 mm	
Approx No. Logs	Up to 6	
	High	Low
Average Heat Output	8.5 kW	6.2 kW
Fuel Consumption Rate	2.38 kg/h	1.65 kg/h
Room Heating Efficiency	63.8%	67.9%

The Serene requires no electrical installation, no additional components and no complex operating requirements.

WALL INSTALLATION

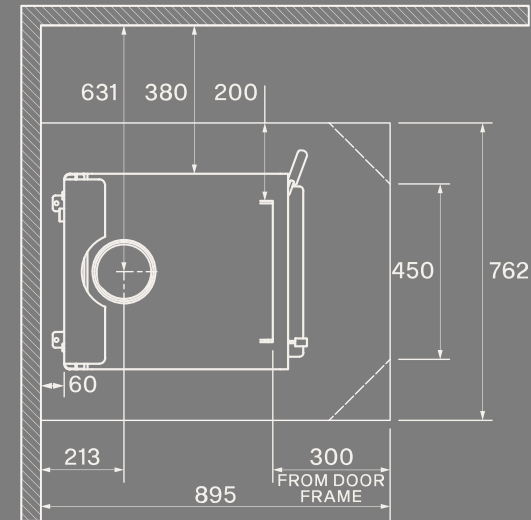

All dimensions and clearances are in mm. Clearances are with factory flue shield.

CORNER INSTALLATION

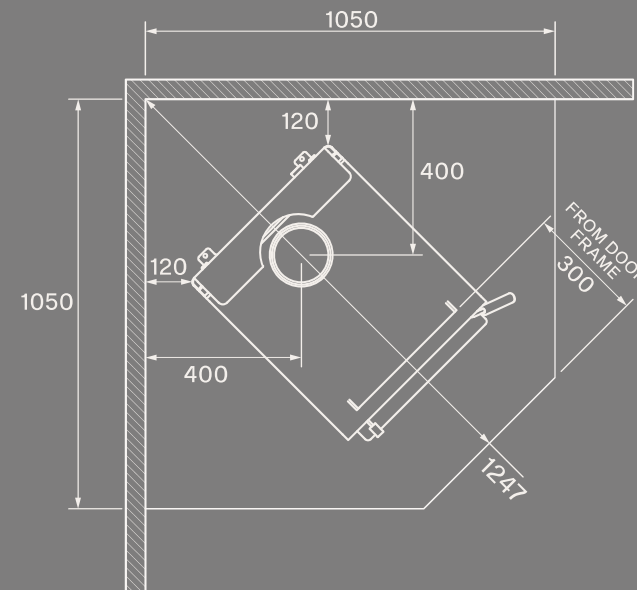

Refer to installation manual for full specifications.

Coleridge

Freestanding Ultra Low Emission Burner

61L

FIREBOX CAPACITY

7 log

FIREBOX CAPACITY

6mm

STEEL COOKTOP

15yr

WOODBBOX WARRANTY

2yr

PARTS WARRANTY

Feels simple and elegant – at home in any large room.

Simplicity is the key and the Coleridge achieves ultra clean burning without the need for fans, or other types of systems that require special operational methods or additional maintenance.

CRAFTED FOR A LONG LIFE

The Coleridge is fitted with stainless steel air tubes and baffle for long service life and has a two year warranty.

ULTRA LOW EMISSIONS – FEEL BETTER ABOUT THE ENVIRONMENT

The Coleridge outperforms the testing standards for emissions, meaning it can be installed in any New Zealand home.



	Pedestal	Legs
Height	823	823
Width	615	648
Depth	638	638



USER FRIENDLY AND EASY TO MAINTAIN

The Coleridge's design is ergonomic and promotes cost-effective ease of use and can be installed in even the tightest of clean air zones in the country.

EASY SERVICE

The simple baffle removal system ensures easy servicing for chimney sweeps.

HANDY STEEL COOKTOP

The Coleridge is fitted with a convenient 6mm steel cooktop suitable for use during a power outage.

Dimensions – Pedestal	823H × 615W × 638D	
– Legs	823H × 648W × 638D	
Weight	150 kg	
ULEB Approved	Yes	
Clean Air Approval	All Zones	
Floor Protector	Ash Hearth	
Max. Log Length	450 mm	
Approx No. Logs	Up to 7	
	High	Low
Average Heat Output	8.9 kW	7.5 kW
Fuel Consumption Rate	2.55 kg/h	1.94 kg/h
Room Heating Efficiency	62.3%	69.6%

The Coleridge requires no electrical installation, no additional components and no complex operating requirements.

WALL INSTALLATION

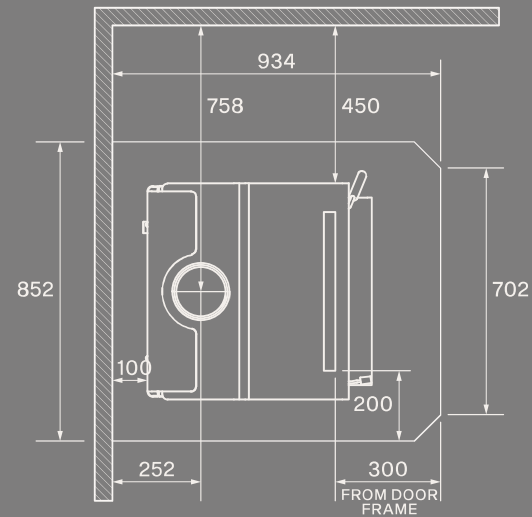

All dimensions and clearances are in mm. Clearances are with factory flue shield.

CORNER INSTALLATION

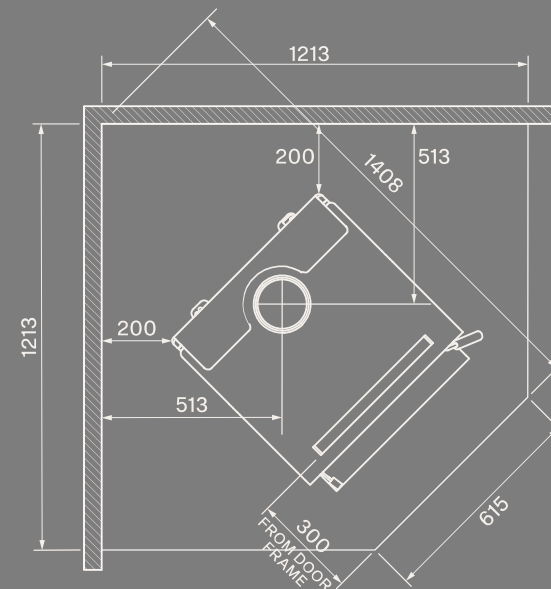

Refer to installation manual for full specifications.

Flare

Freestanding Low Emission
Approved Burner

56L

FIREBOX
CAPACITY

6 log

FIREBOX
CAPACITY

6mm

STEEL
COOKTOP

15yr

WOODB
WARRANTY

2yr

PARTS
WARRANTY

Feels colourful
and stylish –
like you're making
a statement.

WOOD BOX

Red Brown



LEGS

Metallic Brown



The Flare lets you choose the form and colour accent that best suits you with three base options and three accent options available.

CRAFTED FOR A LONG LIFE

The Flare is fitted with a stainless steel baffle for long service life and comes with a two year warranty.

CLEAN AIR APPROVED – FEEL BETTER ABOUT THE ENVIRONMENT

The Flare outperforms the National Environmental Standards for emissions and efficiency.

Height 780

Width 630

Depth 602

COLOUR OPTIONS

Red Brown
Metallic Brown
Charcoal

PEDESTAL
Charcoal



USER FRIENDLY AND EASY TO MAINTAIN

The Flare's design is ergonomic and promotes cost-effective ease of use.

EASY SERVICE

The simple baffle removal system ensures easy servicing for chimney sweeps.

HANDY STEEL COOKTOP

The Flare is fitted with a convenient hidden 6mm steel cooktop suitable for use during a power outage.

Dimensions	780H × 630W × 602D	
Weight	140 kg	
ULEB Approved	No	
Clean Air Approval	Yes (except 0.7 Zones)	
Floor Protector	Ash Hearth	
Max. Log Length	450 mm	
Approx No. Logs	Up to 6	
	High	Low
Average Heat Output	12.0 kW	9.1 kW
Fuel Consumption Rate	3.38 kg/h	2.27 kg/h
Room Heating Efficiency	64.1%	72.4%

The Flare requires no electrical installation, no additional components and no complex operating requirements.

WALL INSTALLATION

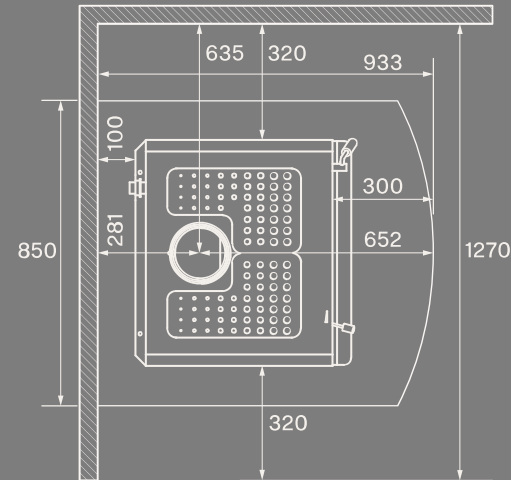

All dimensions and clearances are in mm. Clearances are with factory flue shield.

CORNER INSTALLATION

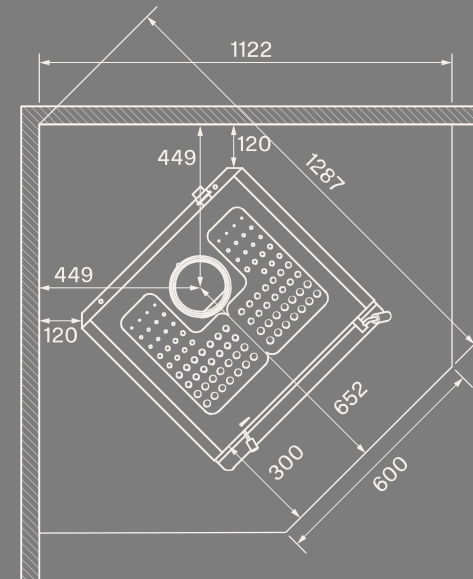

Refer to installation manual for full specifications.

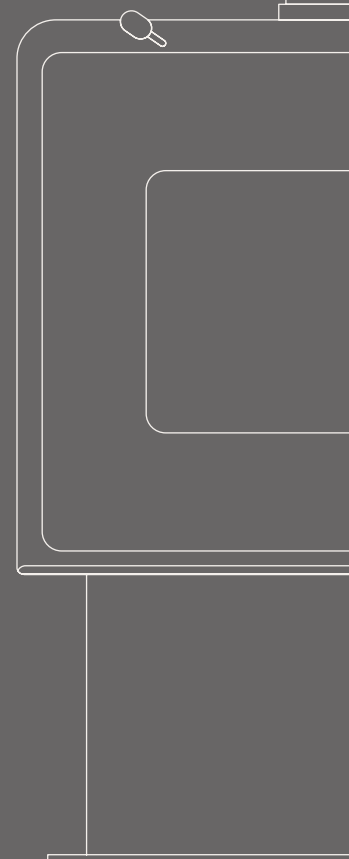

Tasman MkII

Freestanding Low Emission
Approved Burner

56L

FIREBOX
CAPACITY

6 log

FIREBOX
CAPACITY

6mm

STEEL
COOKTOP

15yr

WOODB
WARRANTY

2yr

PARTS
WARRANTY

Feels like the right
mix of traditional
and contemporary.



Height 808

Width 615

Depth 630

Designed for medium to large living areas, the Tasman places a classic wood burner design upon a modern, easy-clean pedestal base.

CRAFTED FOR A LONG LIFE

The Tasman is fitted with a stainless steel baffle for long service life and comes with a two year warranty.

CLEAN AIR APPROVED – FEEL BETTER ABOUT THE ENVIRONMENT

The Tasman MkII outperforms the National Environmental Standards for emissions and efficiency.



USER FRIENDLY AND EASY TO MAINTAIN

The Tasman's design is ergonomic and promotes cost-effective ease of use.

EASY SERVICE

The simple baffle removal system ensures easy servicing for chimney sweeps.

HANDY STEEL COOKTOP

The Tasman is fitted with a convenient 6mm steel cooktop suitable for use during a power outage.

Dimensions	808H × 615W × 630D	
Weight	140 kg	
ULEB Approved	No	
Clean Air Approval	Yes	
Floor Protector	Ash Hearth	
Max. Log Length	450 mm	
Approx No. Logs	Up to 6	
	High	Low
Average Heat Output	14.3 kW	8.4 kW
Fuel Consumption Rate	4.04 kg/h	2.05 kg/h
Room Heating Efficiency	64.4%	78.1%

The Tasman requires no electrical installation, no additional components and no complex operating requirements.

WALL INSTALLATION

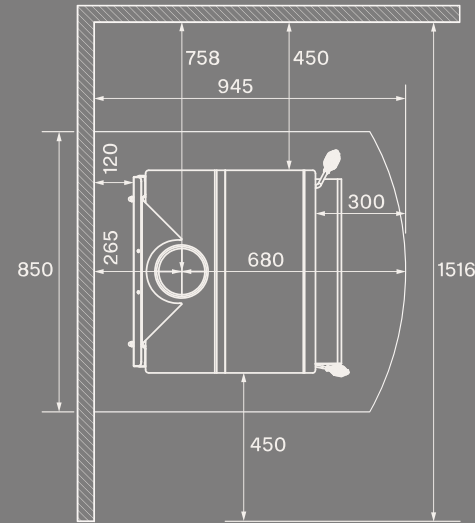

All dimensions and clearances are in mm. Clearances are with factory flue shield.

CORNER INSTALLATION

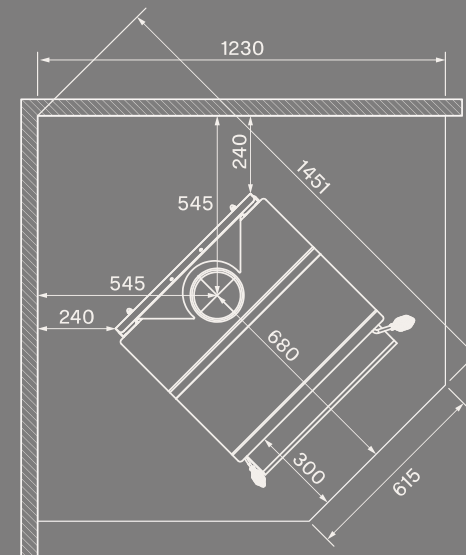

Refer to installation manual for full specifications.

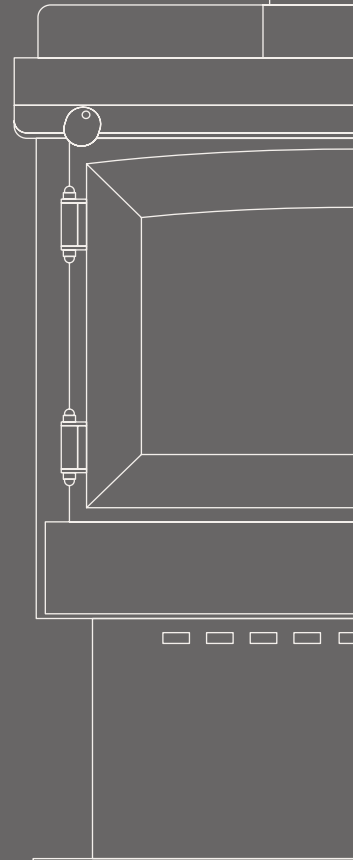

Tarras MkIII

Freestanding Low Emission
Approved Burner

76L

FIREBOX
CAPACITY

10 log

FIREBOX
CAPACITY

8mm

STEEL
COOKTOP

15yr

WOODB
WARRANTY

2yr

PARTS
WARRANTY

Feels warm and
cosy – right in a
big room setting.

Designed to heat large living areas quickly and efficiently, the Tarras MkIII is a cost-effective workhorse (with thoroughbred good looks) that gets the job done and keeps everyone cosy.

CRAFTED FOR A LONG LIFE

The Tarras is fitted with a stainless steel baffle for long service life and comes with a two year warranty.

CLEAN AIR APPROVED – FEEL BETTER ABOUT THE ENVIRONMENT

The Tarras MkIII outperforms the National Environmental Standards for emissions and efficiency.



Height 824

Width 765

Depth 640



USER FRIENDLY AND EASY TO MAINTAIN

The Tarras's design is ergonomic and promotes cost-effective ease of use.

EASY SERVICE

The simple baffle removal system ensures easy servicing for chimney sweeps.

HANDY STEEL COOKTOP

The Tarras is fitted with a convenient 8mm steel cooktop suitable for use during a power outage.

Dimensions	824H × 765W × 640D	
Weight	160 kg	
ULEB Approved	No	
Clean Air Approval	Yes	
Floor Protector	Ash Hearth	
Max. Log Length	600 mm	
Approx No. Logs	Up to 10	
	High	Low
Average Heat Output	16.9 kW	10.6 kW
Fuel Consumption Rate	4.86 kg/h	2.56 kg/h
Room Heating Efficiency	63.1%	74.1%

The Tarras requires no electrical installation, no additional components and no complex operating requirements.

WALL INSTALLATION

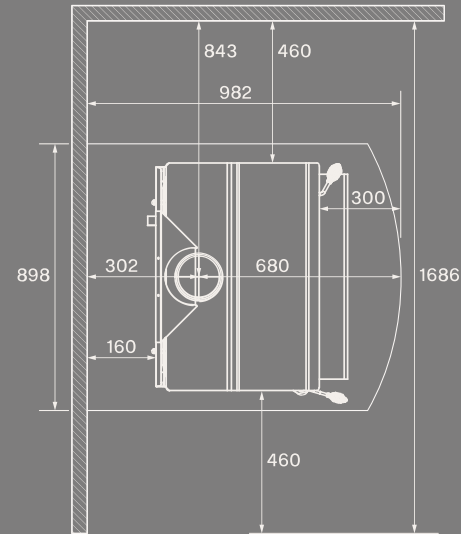

All dimensions and clearances are in mm.
Clearances are with factory flue shield.

CORNER INSTALLATION

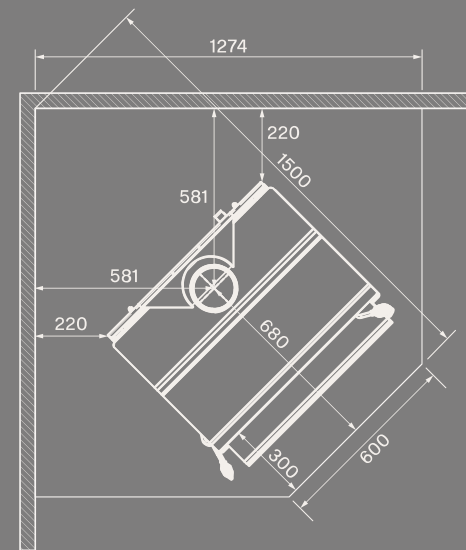

Refer to installation manual for full specifications.

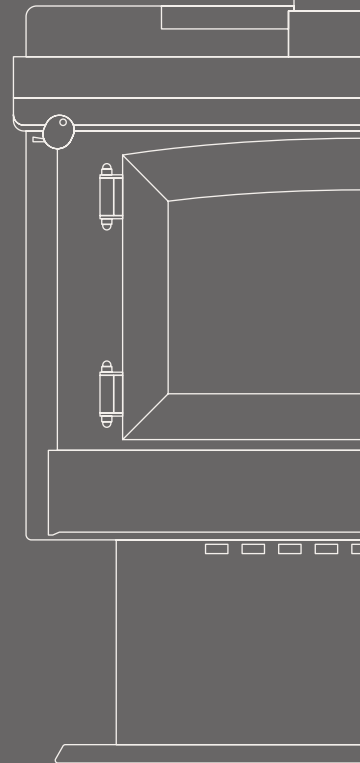

Totara

Fireplace Insert Low Emission Approved Burner

33L

FIREBOX
CAPACITY

2 log

FIREBOX
CAPACITY

6mm

STEEL
FIREBOX

15yr

WOODB
WARRANTY

2yr

PARTS
WARRANTY

Feels like the ideal
upgrade from your
brick fireplace.

It's the perfect option for upgrading your brick open fireplace or a stylish choice for keeping your modern home snug and warm.

CRAFTED FOR A LONG LIFE

The Totara is fitted with a stainless steel baffle for long service life and comes with a two year warranty.

CLEAN AIR APPROVED – FEEL BETTER ABOUT THE ENVIRONMENT

The Totara outperforms the National Environmental Standards for emissions and efficiency.



FASCIA

Height 650

Width 840

Depth 62

USER FRIENDLY AND EASY TO MAINTAIN

The Totara's design is ergonomic and promotes cost-effective ease of use.

EASY SERVICE

The simple baffle removal system ensures easy servicing for chimney sweeps.

INSTALLATION OPTION

Zero clearance box available (for timber framing).

Dimensions	650H × 840W × 62D	
Weight	90 kg	
ULEB Approved	No	
Clean Air Approval	Yes (except 0.7 Zones)	
Floor Protector	8mm Ceramic Tiles	
Max. Log Length	450 mm	
Approx No. Logs	Up to 2	
	High	Low
Average Heat Output	7.3 kW	4.7 kW
Fuel Consumption Rate	2.26 kg/h	1.13 kg/h
Room Heating Efficiency	57.5%	75.2%

The Totara requires no electrical installation, no additional components and no complex operating requirements.

INSTALLATION

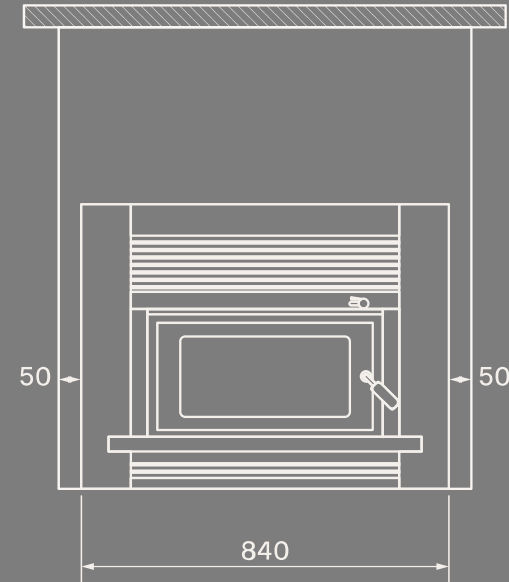

All dimensions and clearances are in mm. Clearances are with factory flue shield.

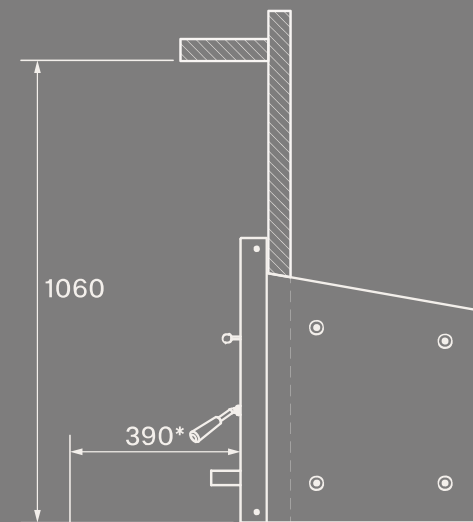

* SEE GRAPH IN INSTALLATION INSTRUCTIONS

Refer to installation manual for full specifications.

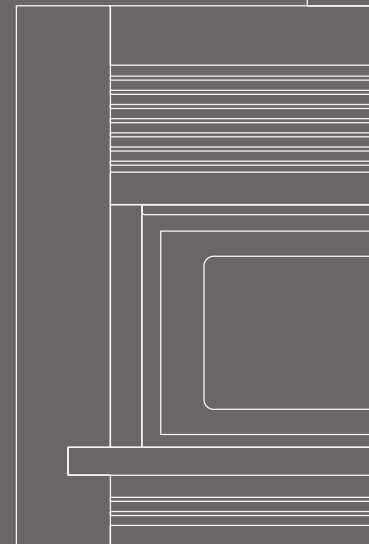

Strongman

Freestanding Multi-fuel Burner

The Strongman is perfect for heating very large rooms and open plan living areas. Its large cooktop allows you to boil a kettle or even cook a pot of soup, a great option if you want to save on electricity.

76L

FIREBOX CAPACITY

8 log

FIREBOX CAPACITY

8mm

STEEL FIREBOX

15yr

WOODBBOX WARRANTY

2yr

PARTS WARRANTY

Dimensions	697H x 715W x 590D
Weight	190 kg
Clean Air Approval	NES Exempt

Max. Log Length	600 mm
Approx No. Logs	Up to 8
Avg. Heat Output	18 kW High 11 kW Low

* Wetback option available.

WALL INSTALLATION

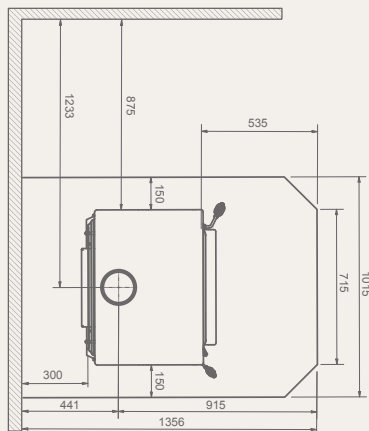

CORNER INSTALLATION

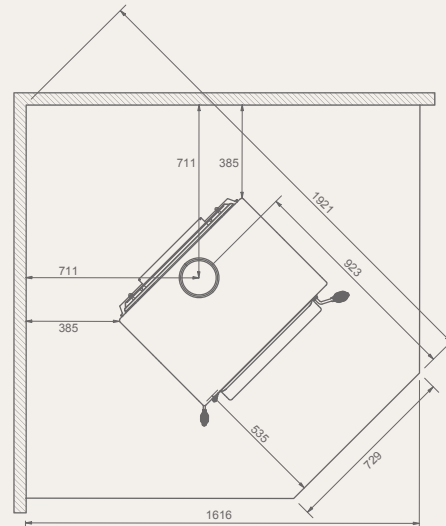

All dimensions and clearances are in mm. Clearances are with factory flue shield. Refer to installation manual for full specifications.



RMF

Freestanding Multi-fuel Burner

The RMF features a unique 'half shell' body exposing the firebox, which provides direct radiant heat with optimum efficiency. The half shell body design allows direct access to the top of the firebox for cooking.

32L

**FIREBOX
CAPACITY**

3 log

**FIREBOX
CAPACITY**

6mm

**STEEL
FIREBOX**

15yr

**WOODBOS
WARRANTY**

2yr

**PARTS
WARRANTY**

Dimensions	618H x 580W x 450D	Max. Log Length	350 mm
Weight	120 kg	Approx No. Logs	Up to 3
Clean Air Approval	NES Exempt	Avg. Heat Output	11 kW High 8 kW Low

* Factory fitted wetback model available.

WALL INSTALLATION

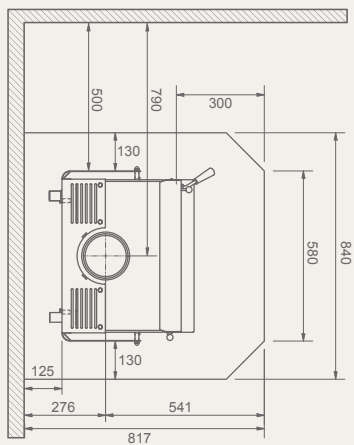

CORNER INSTALLATION

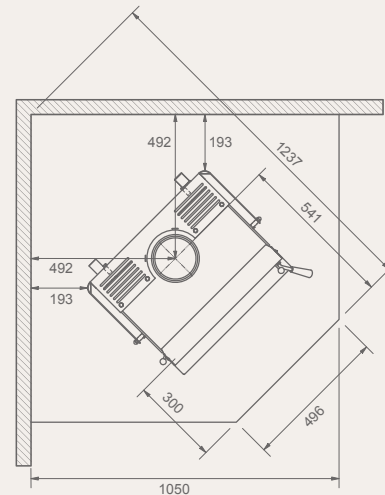

All dimensions and clearances are in mm. Clearances are with factory flue shield. Refer to installation manual for full specifications.



The Stag

Freestanding Multi-fuel Burner

Designed specially for rugged South Island conditions and fitted with a sturdy cast iron door, The Stag provides the reliability you need. This rugged multi-fuel fire combines style, performance, efficiency and flexibility – with a cooktop and wet back option.

56L

**FIREBOX
CAPACITY**

6 log

**FIREBOX
CAPACITY**

6mm

**STEEL
FIREBOX**

15yr

**WOODB
WARRANTY**

2yr

**PARTS
WARRANTY**

Dimensions	727H x 615W x 622D	Max. Log Length	400 mm
Weight	160 kg	Approx No. Logs	Up to 6
Clean Air Approval	NES Exempt	Avg. Heat Output	15 kW High 9 kW Low

* Wetback option available.

WALL INSTALLATION

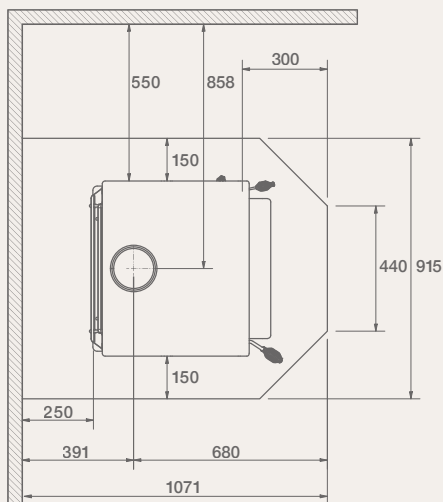

CORNER INSTALLATION

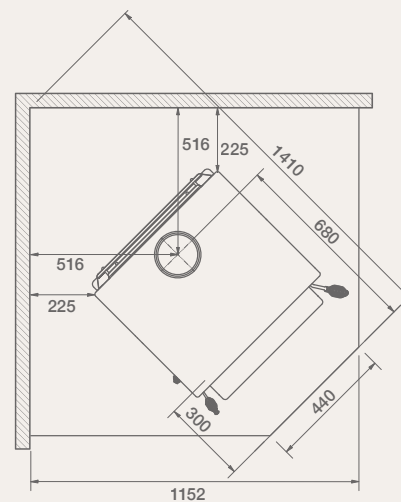

All dimensions and clearances are in mm. Clearances are with factory flue shield. Refer to installation manual for full specifications.



The Coaster

Freestanding Multi-fuel Burner

The Coaster provides the reliability you need, when keeping warm can be a matter of life or death. This rugged multi-fuel fire combines value, performance, efficiency and flexibility – with a cooktop and wet back option. Designed for challenging environments.

56L

**FIREBOX
CAPACITY**

6 log

**FIREBOX
CAPACITY**

6mm

**STEEL
FIREBOX**

15yr

**WOODB
WARRANTY**

2yr

**PARTS
WARRANTY**

Dimensions	727H x 615W x 622D	Max. Log Length	400 mm
Weight	160 kg	Approx No. Logs	Up to 6
Clean Air Approval	NES Exempt	Avg. Heat Output	15 kW High 9 kW Low

* Wetback option available.

WALL INSTALLATION

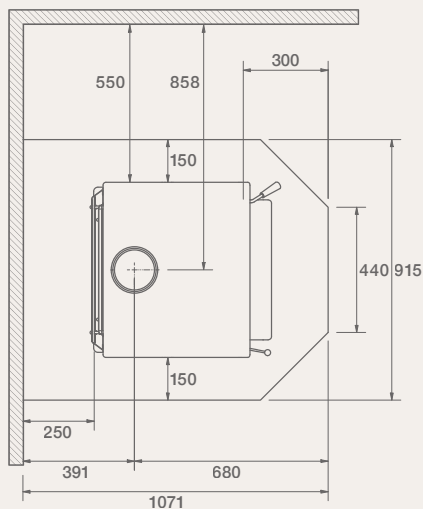

CORNER INSTALLATION

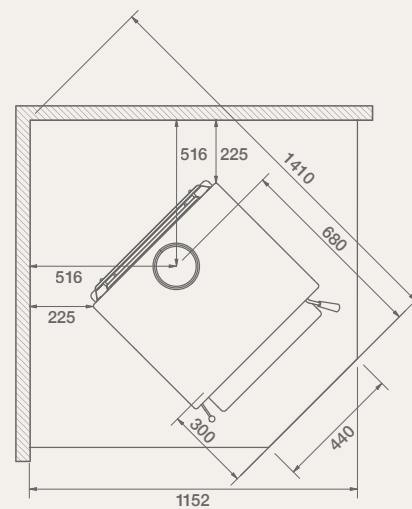

All dimensions and clearances are in mm. Clearances are with factory flue shield. Refer to installation manual for full specifications.





Parts & Accessories

Keep your fire performing at its peak with our comprehensive range of genuine parts and lifestyle accessories. From essential replacement baffles, fire bricks and door seals, we provide everything needed to maintain safety and efficiency. Beyond maintenance, explore our curated accessories. By choosing authentic Woodsman components, you ensure the longevity of your wood burner for many winters to come.

You can purchase our quality accessories from our approved retailer or from our website, [woodsman.co.nz/shop](https://www.woodsman.co.nz/shop)







SUPPLIED BY:

WOODSMAN

**Handcrafted in
New Zealand**

since 1887



41 Braddon Street
Christchurch

+64 3 366 17 96
0800 366 17 96

sales@woodsman.co.nz
woodsman.co.nz